

## PROFIBUS-DP Slave Interface Modules

**proficonn**<sup>®</sup>

- SPI interface (up to 6 MBit/s)
- Isolated RS485 Interface up to 12 MBit/s
- Status LEDs for Power and DataExchange
- Vcc 3.3V
- Supporting PROFIBUS-DP-V0, DP-V1 and DP-V2
- 4kB communication RAM
- Software stack

### proficonn-DSUB

- With 9-pin DSUB-connector for direct enclosure mounting
- Flat cable connector for SPI communication and power supply
- Dimensions: 58 x 31 x 16 mm

### proficonn-DIP28

- 28 pin Dual-Inline-Package format
- for mounting on PCB via standard IC socket
- Dimensions: 36 x 18 x 10 mm

## Overview

**proficonn-DSUB** and **proficonn-DIP28** are very compact PROFIBUS-DP slave interface modules based on profichip's VPC3+S protocol ASIC. Both modules provide a complete, PROFIBUS approved RS485 interface including DC/DC converter and isolated line driver.

Efficient and signal saving communication with the customer application is accomplished by means of a serial SPI channel. For more details please refer to the VPC3+S User Manual.

## Block Diagramm

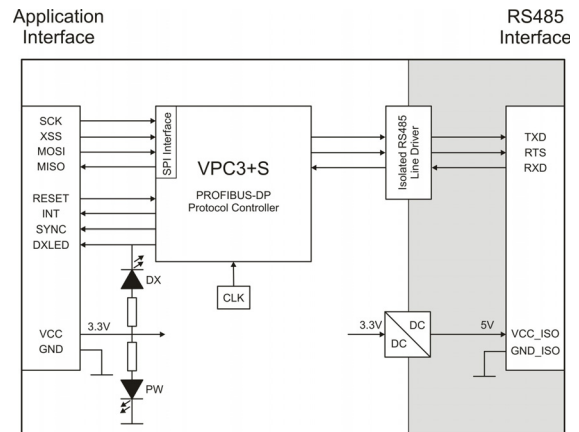

## proficonn DIP28

The proficonn-DIP28 module is based on a standard DIP28 footprint. The module can be mounted on the PCB directly or plugged into a standard IC socket.

Pin	Signal Name	In/Out	Description	Connect to
1	SYNC	O	ISOM Synchronization Pulse	CPU IRQ or OPEN
2	RESET	I	Master-Reset	CPU Port Pin
3	SPI_XSS	I	SPI Slave-Select Signal (active low)	CPU Slave-Select
4	SPI_MISO	O	SPI Master-In-Slave-Out (Serial Data Output)	CPU MISO
5	SPI_SCK	I	SPI Serial Clock	CPU SCK
6	SPI_MOSI	I	Master-Out-Slave-In (Serial Data Input)	CPU MOSI
7	RESERVED	I	Reserved	GND
8	n.c.		Not connected	
9	n.c.		Not connected	
10	GND_ISO		Ground (isolated)	PB-Interface
11	VCC_ISO		VCC 5V (isolated)	PB-Interface
12	PB_RTS	O	Request-To-Send	PB-Interface
13	PB_A	IO	PROFIBUS A-Line	PB-Interface
14	PB_B	IO	PROFIBUS B-Line	PB-Interface
15	SHIELD		Shield	PB-Interface/Housing
16	n.c.		Not connected	
17	n.c.		Not connected	
18	VCC		3.3V Power Supply	3.3V
19	GND		GND Power Supply	GND
20	n.c.		Not connected	
21	n.c.		Not connected	
22	INT	O	Interrupt Request	CPU / IRQ Controller
23	XDATAEXCH	O	Indicates state 'Data-Exchange' (active low)	LED or OPEN
24	SPI_CPHA	I	SPI Clock Phase	VCC or GND / OPEN
25	SPI_CPOL	I	SPI Clock Polarity	VCC or GND / OPEN
26	RESERVED	I	Reserved	GND
27	RESERVED	I	Reserved	GND
28	RESERVED	I	Reserved	GND

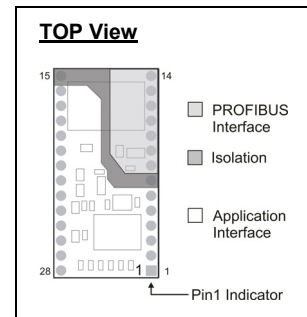

### Notes:

All signals beginning with 'X' are LOW active.

VCC = +3.3 V, GND = 0 V

SPI\_CPHA and SPI\_CPOL have on-board pull-down resistors (4K7) and can be left unconnected (SPI Mode 0) or selectively connected to VCC (SPI Mode 1 to 3).

## proficonn DSUB

The proficonn-DSUB module is suited for direct enclosure mounting via shielded 9-pin DSUB female connector (X1). A 10-pin 2.54 mm male socket (X2) is provided to connect to the device electronic via flat ribbon cable.

### Profibus Interface (X1)

Pin	Signal Name	In/Out	Description	Connect to
1	n.c.		Not connected	
2	n.c.		Not connected	
3	PB_B	IO	PROFIBUS B-Line	PB-Interface
4	PB_RTS	O	Request-To-Send	PB-Interface
5	GND_ISO		Ground (isolated)	PB-Interface
6	VCC_ISO		VCC 5V (isolated)	PB-Interface
7	n.c.		Not connected	
8	PB_A	IO	PROFIBUS A-Line	PB-Interface
9	n.c.		Not connected	
	SHIELD		Shield	Housing

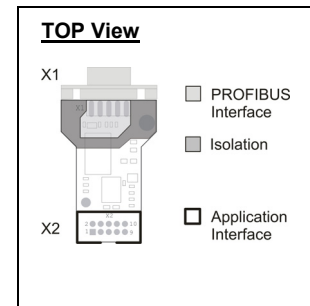

### Application Interface (X2)

Pin	Signal Name	In/Out	Description	Connect to
1	VCC		3.3V Power Supply	3.3V
2	GND		GND Power Supply	GND
3	RESET	I	Master-Reset	CPU port pin
4	SPI_MISO	O	SPI Master-In-Slave-Out (Serial Data Output)	CPU MISO
5	XDATAEXCH	O	Indicates state 'Data-Exchange' (active low)	LED or OPEN
6	SPI_SCK	I	SPI Serial Clock	CPU SCK
7	SYNC	O	ISOM Synchronization Pulse	CPU IRQ or OPEN
8	SPI_MOSI	I	Master-Out-Slave-In (Serial Data Input)	CPU MOSI
9	INT	O	Interrupt Request	CPU / IRQ Controller
10	SPI_XSS	I	SPI Slave-Select Signal (active low)	CPU Slave-Select

#### Notes:

All signals beginning with 'X' are LOW active.

VCC = +3.3 V, GND = 0 V

## Operating Conditions

Parameter	Symbol	MIN	TYP	MAX	Unit
DC supply voltage	VCC	3.00	3.30	3.60	V
Circuit ground	GND	0		0	V
Input voltage (HIGH level)	V <sub>IH</sub>	2.00	3.30	5.50 <sup>1)</sup>	V
Input voltage (LOW level)	V <sub>IL</sub>	0		0.8	V
Output voltage	V <sub>O</sub>	0		VCC	V
Input LOW current	I <sub>IL</sub>	-1		+1	μA
Input HIGH current	I <sub>IH</sub>	-1		+1	μA
Output current LOW level	I <sub>OL</sub>	+8			mA
Output current HIGH level	I <sub>OH</sub>	-8			mA
Current consumption	I <sub>A</sub>		75 <sup>2)</sup> 115 <sup>3)</sup>		mA
Ambient temperature	T <sub>A</sub>	-40		+85	°C

<sup>1)</sup>: 5V tolerant inputs

<sup>2)</sup>: no Profibus network connected

<sup>3)</sup>: Profibus network connected and termination active

The information in this document is subject to change without notice. The data and illustrations are not binding.